

MUMS Series Lowest Inertia

Motor Output Range

30W, 50W, 100W, 200W, 400W, 750W

Super Low Inertia Type

Rated Speed: 3000rpm

Maximum Speed: 4500/5000rpm

Torque: From 2.48 to 62.88 lb-in at peak

Applicable Amplifier

Use with [MUDS Driver](#)

Explanation of Part Numbers

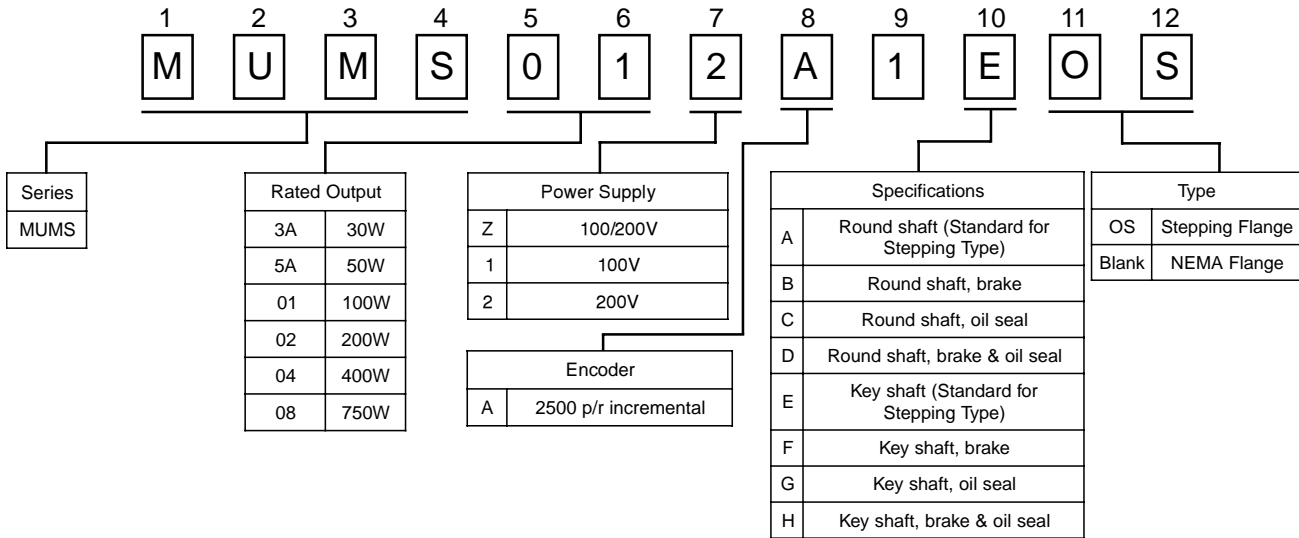

Design and specifications are subject to change without notice. Ask Panasonic for technical specifications before purchase and/or use. Whenever a doubt about safety arises from this product, please contact Panasonic immediately for technical consultation.

Motor / Driver Options

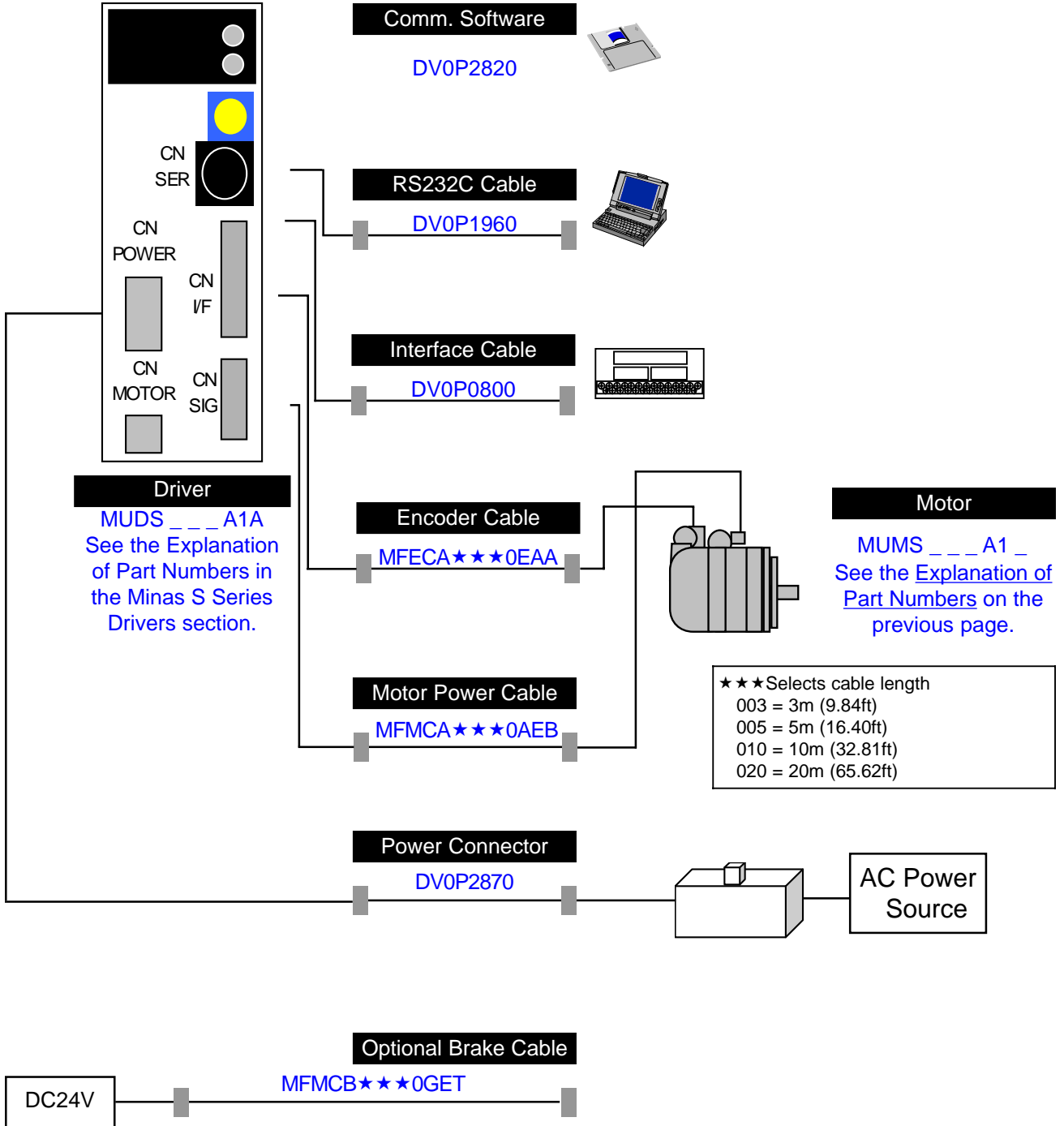

Motor / Driver Options

Communications Software	DV0P2820		
RS232C Cable	DV0P1960		
Interface Cable	DV0P0800		
Encoder Cable	MFECA★★★0EEA	2500p/r incremental for 30 - 750W	★★★ Cable length
Motor Power Cable	MFMCA★★★0AEB	30 - 750W	
Brake Cable (Optional)	MFMCB★★★0GET	30 - 750W (add'l brake cable)	
Motor	MUMS _ _ _ A1 _ MUMS _ _ _ A1 _ 0S	2500p/r incremental	See Explanation of Part Numbers
Driver	MUDS _ _ _ A1A	2500p/r incremental	See Explanation of Part Numbers in the Minas S Series Drivers section
Connectors (Optional)		For customer supplied cables. See the Minas S Series Accessories section	

MUMS3AZ□□□ - 30W/100V or 200V

Specifications

Torque	Rated	N. m	0.095
		lb-in.	0.84
	Maximum	N. m	0.28
		lb-in.	2.48
Rotor Inertia	Without Brake	x10kg. ⁴ m ²	0.016
		lb. in ²	0.005
	With Brake	x10kg. ⁴ m ²	0.020
		lb. in ²	0.007
Speed	Rated	r/min.	3000
	Maximum	r/min.	5000
Weight	Without Brake	kg	0.3
		lb	0.66
	With Brake	kg	0.5
		lb	1.1
Current	Rated	A(rms)	1.0
	Maximum	A(0-P)	4.3
Power Rating	Without Brake	kW/s	5.8
	With Brake	kW/s	4.6
Brake (Option)	Voltage	V	DC 24 ± 2.4
	Current	DC, A	0.26
	Static Friction Torque	N. m	0.29 or higher
		lb-in	2.57 or higher

Note: Separate power source required for brake (DC24V)

Speed - Torque Curve

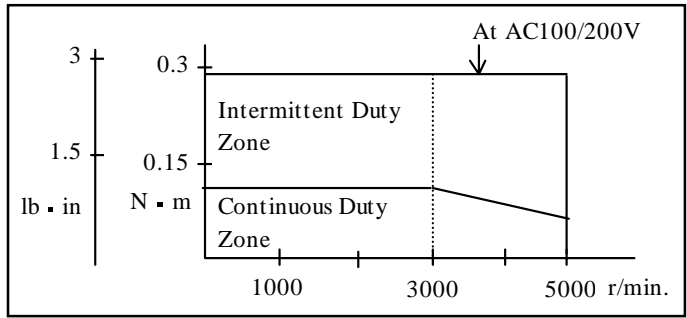

Temperature Characteristics

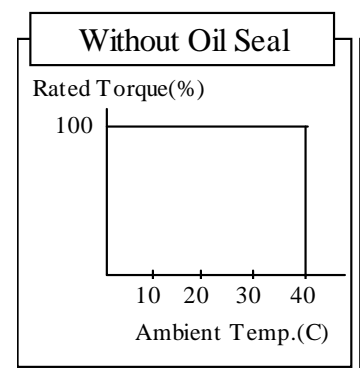

Permissible Radial and Thrust Loads

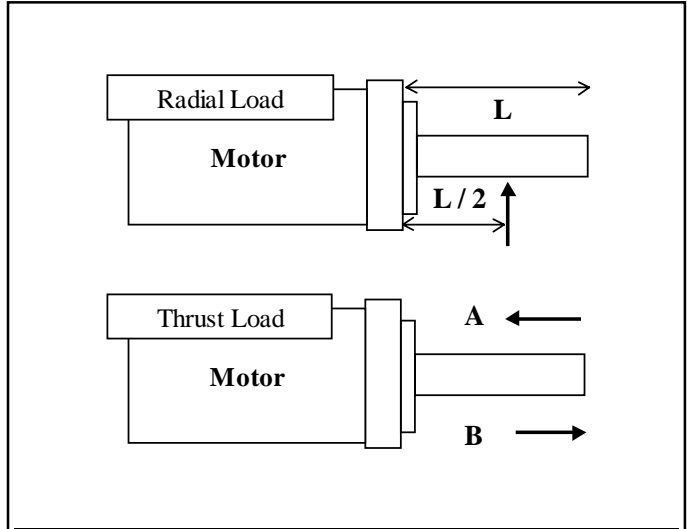

During Installation of Motor			During Operation of Motor	
Radial Load	Thrust A	Thrust B	Radial Load	Thrust Load
147.0 N	88.0 N	117.6 N	49.0 N	29.4 N
33.0 lb	19.8 lb	26.4 lb	11.0 lb	6.6 lb

MUMS3AZ□□□ - 30W/100V or 200V

Dimensions

NEMA Flange #17 Type

Units: mm(in)

Drawing not to scale

Brake	L	LL	LM	KB1
Without	87.5 (3.445)	67.5 (2.657)	39.0 (1.535)	13.8 (0.543)
With	119.0 (4.685)	99.0 (3.898)	70.5 (2.776)	

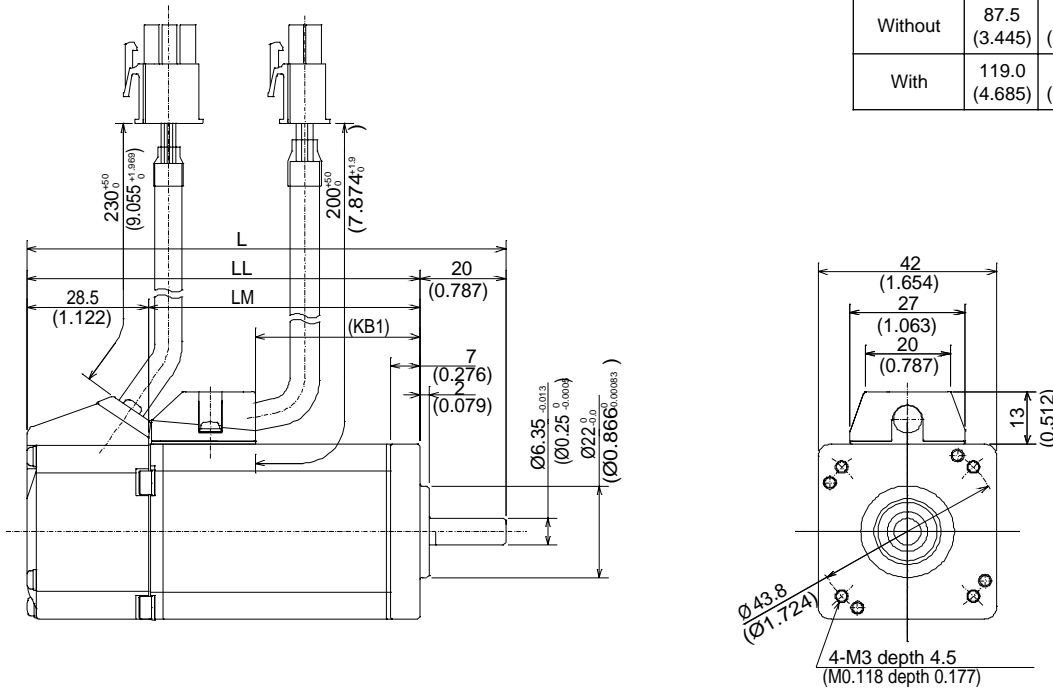

Stepping Flange Type

Drawing not to scale

Brake	L	LL	LM	KB1	S	LW	LK	KW	KH	RH
Without	91.5 (3.602)	67.5 (2.657)	39.0 (1.535)	13.8 (0.543)	7.0 (0.276)	13.0 (0.512)	12.0 (0.472)	2.0 (0.079)	2.0 (0.079)	5.8 (0.228)
With	123.0 (4.843)	99.0 (3.898)	70.5 (2.776)							

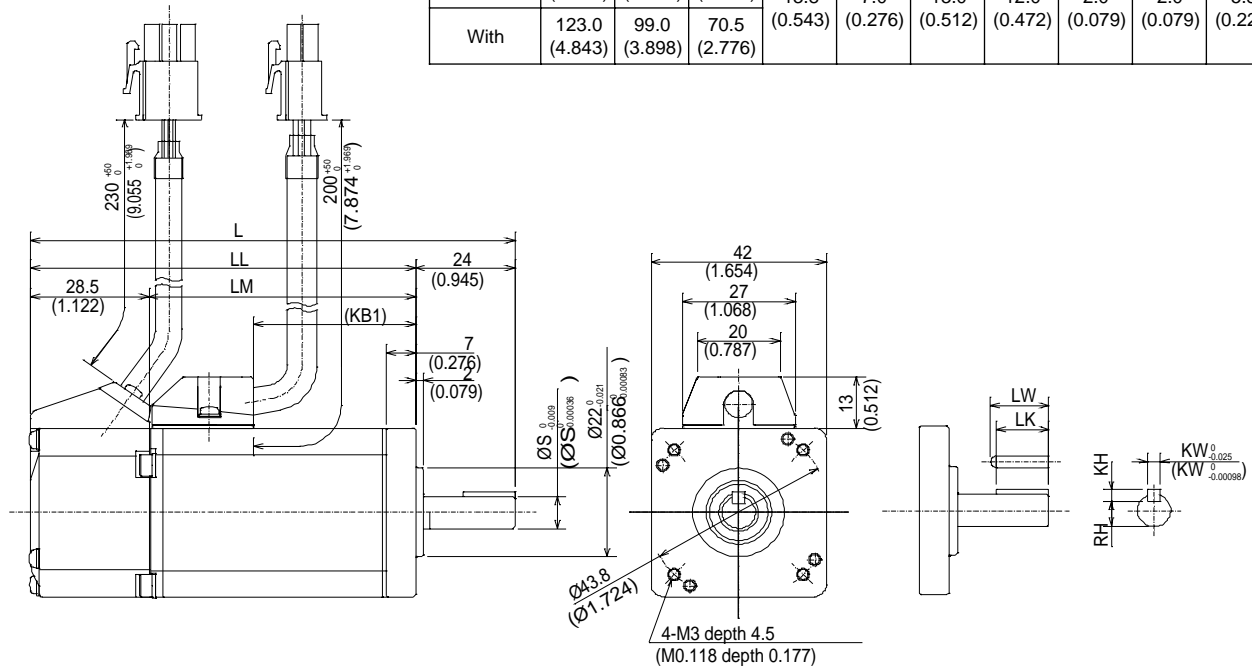

MUMS5AZ□□□ - 50W/100V or 200V

Specifications

Torque	Rated	N. m	0.16
		lb-in.	1.42
	Maximum	N. m	0.48
		lb-in.	4.25
Rotor Inertia	Without Brake	x10kg. ⁻⁴ m ²	0.025
		lb. in ²	0.009
	With Brake	x10kg. ⁻⁴ m ²	0.030
		lb. in ²	0.010
Speed	Rated	r/min.	3000
	Maximum	r/min.	5000
Weight	Without Brake	kg	0.4
		lb	0.88
	With Brake	kg	0.6
		lb	1.32
Current	Rated	A(rms)	1.0
	Maximum	A(0-P)	4.3
Power Rating	Without Brake	kW/s	9.9
	With Brake	kW/s	8.3
Brake (Option)	Voltage	V	DC 24 ± 2.4
	Current	DC, A	0.26
	Static Friction Torque	N. m	0.29 or higher
lb-in		2.57 or higher	

Note: Separate power source required for brake (DC24V)

Speed - Torque Curve

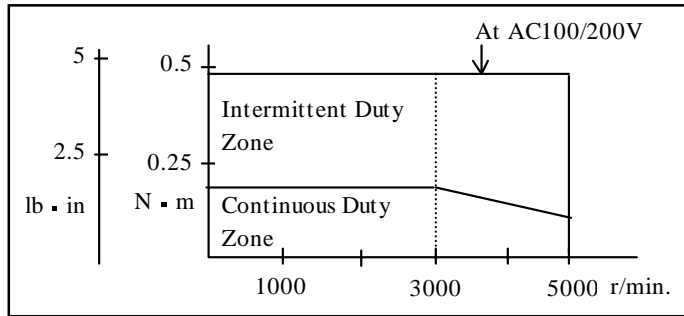

Temperature Characteristics

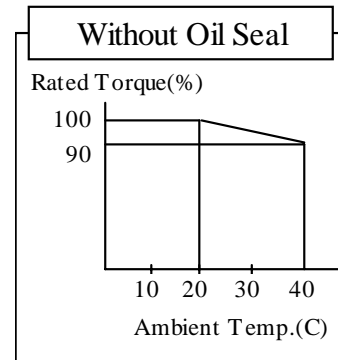

Permissible Radial and Thrust Loads

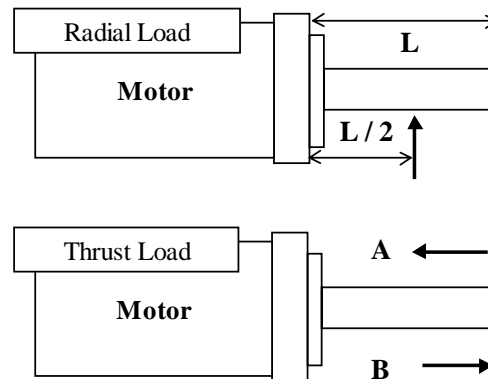

During Installation of Motor			During Operation of Motor	
Radial Load	Thrust A	Thrust B	Radial Load	Thrust Load
147.0 N	88.0 N	117.6 N	68.6 N	58.8 N
33.0 lb	19.8 lb	26.4 lb	15.4 lb	13.2 lb

MUMS5AZ□□□ - 50W/100V or 200V

Dimensions

NEMA Flange #17 Type

Units: mm(in)

Drawing not to scale

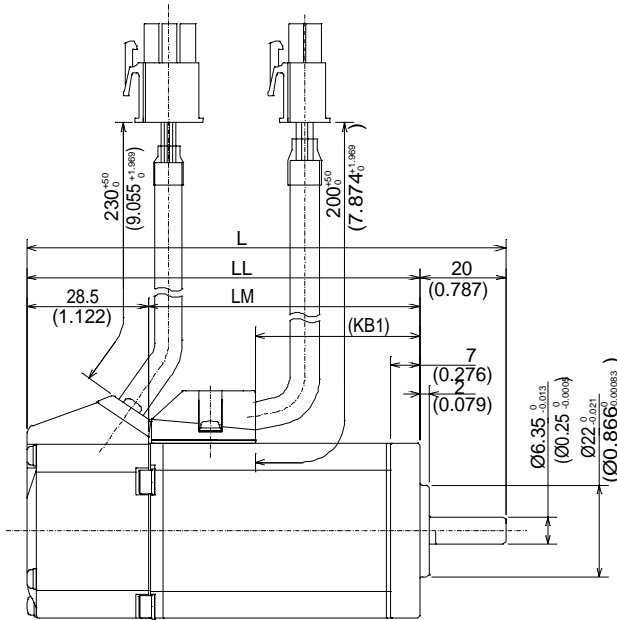

Brake	L	LL	LM	KB1
Without	95.5 (3.760)	75.5 (2.972)	47.0 (1.850)	21.8 (0.858)
With	127.0 (5.000)	107.0 (4.213)	78.5 (3.091)	

Stepping Flange Type

Drawing not to scale

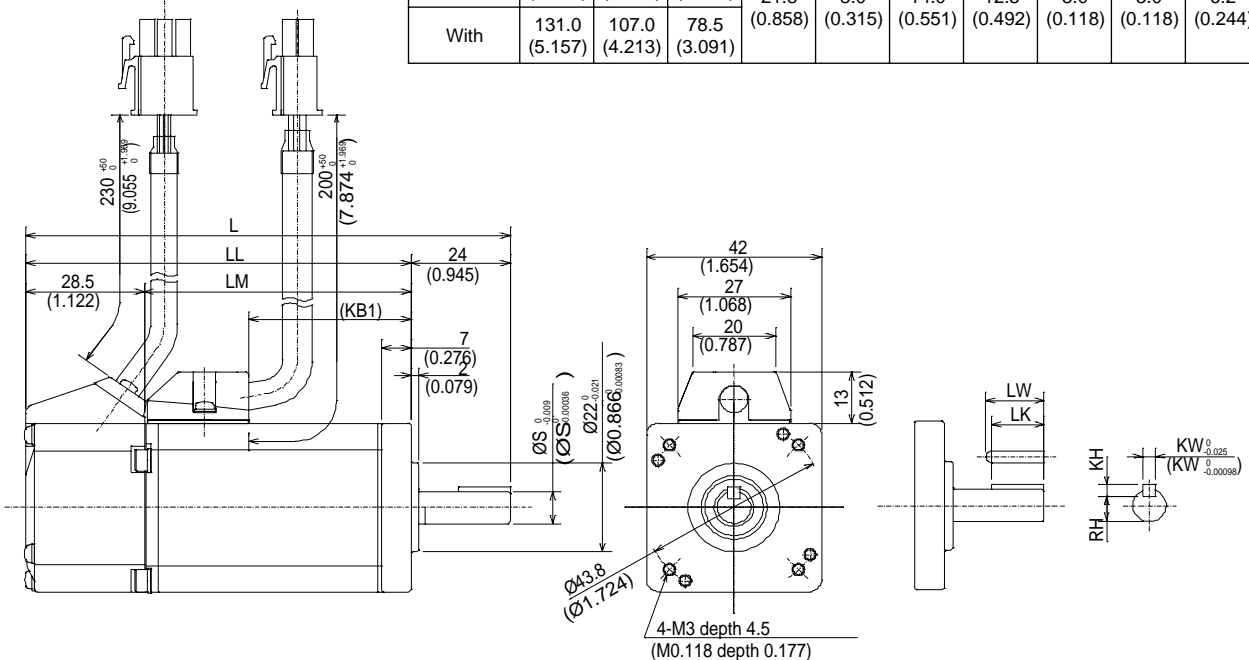

Brake	L	LL	LM	KB1	S	LW	LK	KW	KH	RH
Without	99.5 (3.917)	75.5 (2.972)	47.0 (1.850)	21.8 (0.858)	8.0 (0.315)	14.0 (0.551)	12.5 (0.492)	3.0 (0.118)	3.0 (0.118)	6.2 (0.244)
With	131.0 (5.157)	107.0 (4.213)	78.5 (3.091)							

MUMS011□□□ - 100W/100V

Specifications

Torque	Rated	N. m	0.32
		lb-in.	2.83
	Maximum	N. m	0.95
		lb-in.	8.41
Rotor Inertia	Without Brake	x10kg. ⁴ m ²	0.044
		lb. in ²	0.015
	With Brake	x10kg. ⁴ m ²	0.048
		lb. in ²	0.016
Speed	Rated	r/min.	3000
	Maximum	r/min.	5000
Weight	Without Brake	kg	0.5
		lb	1.10
	With Brake	kg	0.7
		lb	1.54
Current	Rated	A(rms)	1.6
	Maximum	A(0-P)	6.9
Power Rating	Without Brake	kW/s	23.4
	With Brake	kW/s	21.4
Brake (Option)	Voltage	V	DC 24 ± 2.4
	Current	DC, A	0.26
	Static Friction Torque	N. m	0.29 or higher
lb-in		2.57 or higher	

Note: Separate power source required for brake (DC24V)

Speed - Torque Curve

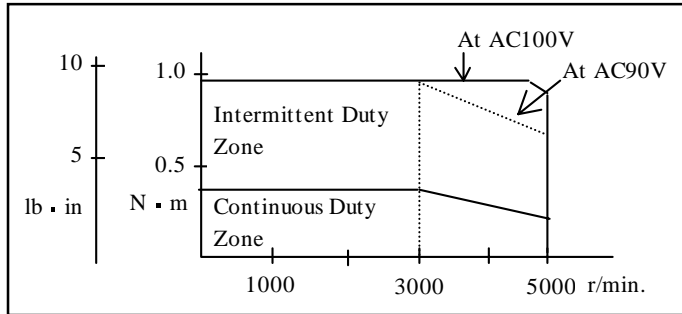

Temperature Characteristics

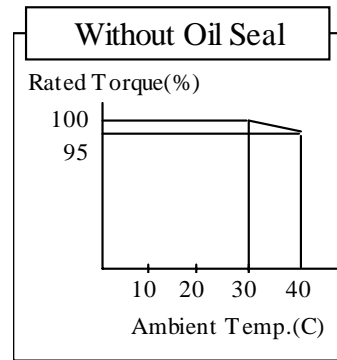

Permissible Radial and Thrust Loads

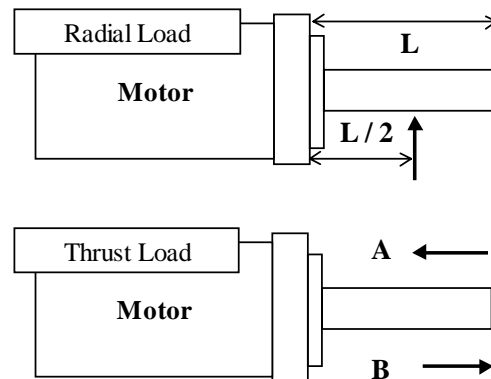

During Installation of Motor			During Operation of Motor	
Radial Load	Thrust A	Thrust B	Radial Load	Thrust Load
147.0 N	88.0 N	117.6 N	68.6 N	58.8 N
33.0 lb	19.8 lb	26.4 lb	15.4 lb	13.2 lb

MUMS011□□ - 100W/100V

Dimensions

NEMA Flange #17 Type

Units: mm(in)

Drawing not to scale

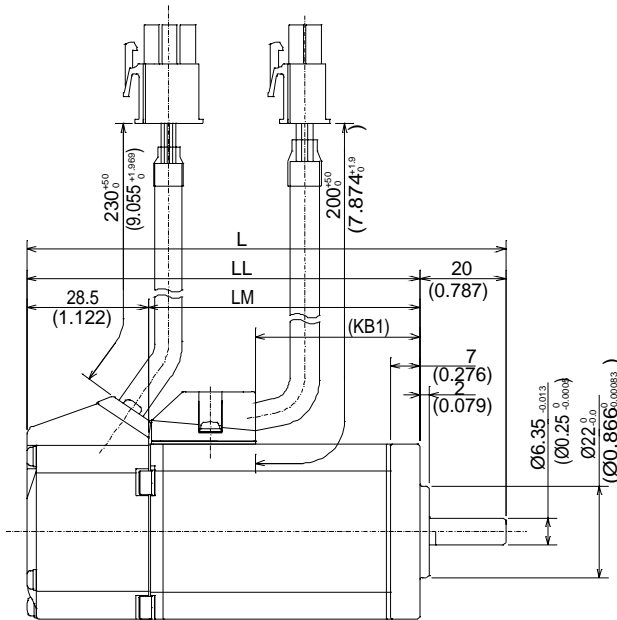

Brake	L	LL	LM	KB1
Without	112.5 (4.429)	92.5 (3.642)	64.0 (2.520)	38.8 (1.528)
With	144.0 (5.669)	124.0 (4.882)	95.5 (3.706)	

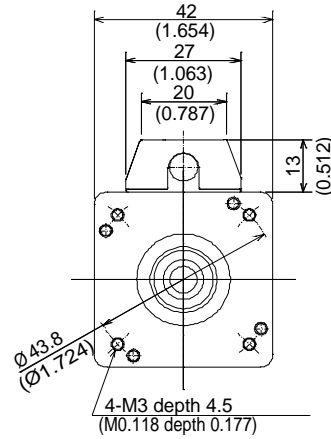

Stepping Flange Type

Drawing not to scale

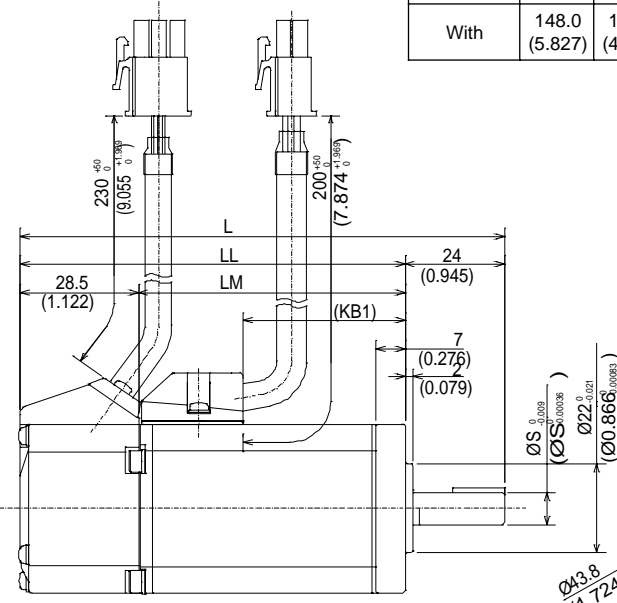

Brake	L	LL	LM	KB1	S	LW	LK	KW	KH	RH
Without	116.5 (4.587)	92.5 (3.642)	64.0 (2.520)	38.8 (1.528)	8.0 (0.315)	14.0 (0.551)	12.5 (0.492)	3.0 (0.118)	3.0 (0.118)	6.2 (0.244)
With	148.0 (5.827)	124.0 (4.882)	95.5 (3.706)							

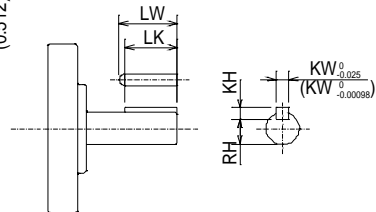
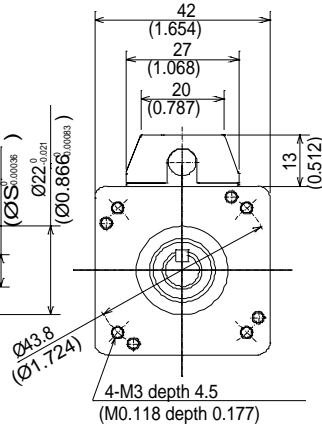

MUMS012□□□ - 100W/200V

Specifications

Torque	Rated	N. m	0.32
		lb-in.	2.83
	Maximum	N. m	0.95
		lb-in.	8.41
Rotor Inertia	Without Brake	$\times 10\text{kg}\cdot\text{m}^2$	0.044
		lb. in ²	0.015
	With Brake	$\times 10\text{kg}\cdot\text{m}^2$	0.048
		lb. in ²	0.016
Speed	Rated	r/min.	3000
	Maximum	r/min.	5000
Weight	Without Brake	kg	0.5
		lb	1.10
	With Brake	kg	0.7
		lb	1.54
Current	Rated	A(rms)	1.0
	Maximum	A(0-P)	4.3
Power Rating	Without Brake	kW/s	23.4
	With Brake	kW/s	21.4
Brake (Option)	Voltage	V	DC 24 ± 2.4
	Current	DC, A	0.26
	Static Friction Torque	N. m	0.29 or higher
lb-in		2.57 or higher	

Note: Separate power source required for brake (DC24V)

Speed - Torque Curve

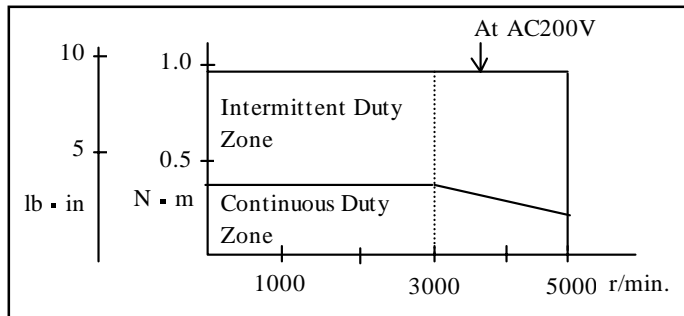

Temperature Characteristics

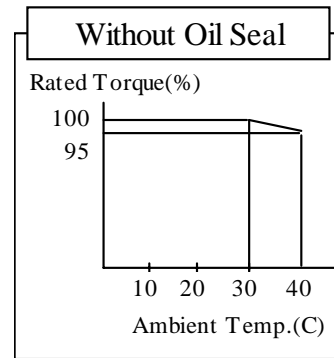

Permissible Radial and Thrust Loads

Radial Load

Thrust Load

During Installation of Motor			During Operation of Motor	
Radial Load	Thrust A	Thrust B	Radial Load	Thrust Load
147.0 N	88.0 N	117.6 N	68.6 N	58.8 N
33.0 lb	19.8 lb	26.4 lb	15.4 lb	13.2 lb

MUMS012□□ - 100W/200V

Dimensions

NEMA Flange #17 Type

Units: mm(in)

Drawing not to scale

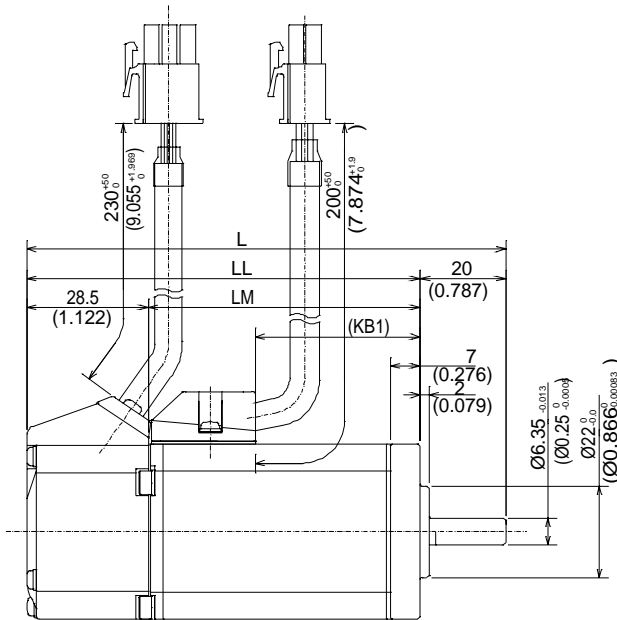

Brake	L	LL	LM	KB1
Without	112.5 (4.429)	92.5 (3.642)	64.0 (2.520)	38.8 (1.528)
With	144.0 (5.669)	124.0 (4.882)	95.5 (3.706)	

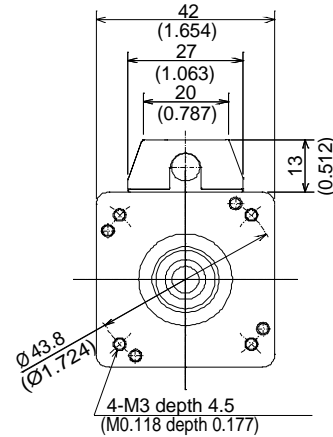

Stepping Flange Type

Drawing not to scale

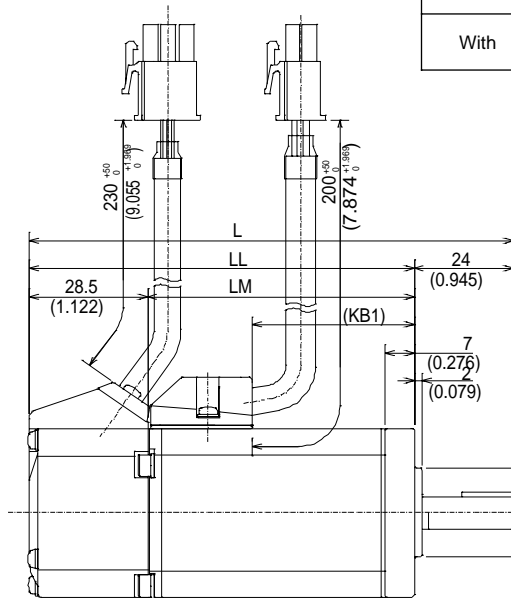

Brake	L	LL	LM	KB1	S	LW	LK	KW	KH	RH
Without	116.5 (4.587)	92.5 (3.642)	64.0 (2.520)	38.8 (1.528)	8.0 (0.315)	14.0 (0.551)	12.5 (0.492)	3.0 (0.118)	3.0 (0.118)	6.2 (0.244)
With	148.0 (5.827)	124.0 (4.882)	95.5 (3.706)							

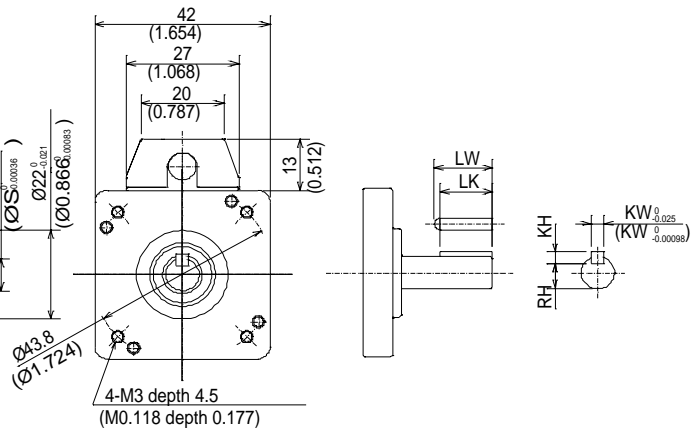

MUMS021□□□ - 200W/100V

Specifications

Torque	Rated	N. m	0.64
		lb-in.	5.67
	Maximum	N. m	1.91
		lb-in.	16.92
Rotor Inertia	Without Brake	x10kg. ⁴ m ²	0.100
		lb. in ²	0.034
	With Brake	x10kg. ⁴ m ²	0.130
		lb. in ²	0.044
Speed	Rated	r/min.	3000
	Maximum	r/min.	5000
Weight	Without Brake	kg	0.96
		lb	2.12
	With Brake	kg	1.36
		lb	3.00
Current	Rated	A(rms)	2.5
	Maximum	A(0-P)	10.5
Power Rating	Without Brake	kW/s	41.4
	With Brake	kW/s	31.9
Brake (Option)	Voltage	V	DC 24 ± 2.4
	Current	DC, A	0.36
	Static Friction Torque	N. m	1.27 or higher
lb-in		11.24 or higher	

Note: Separate power source required for brake (DC24V)

Speed - Torque Curve

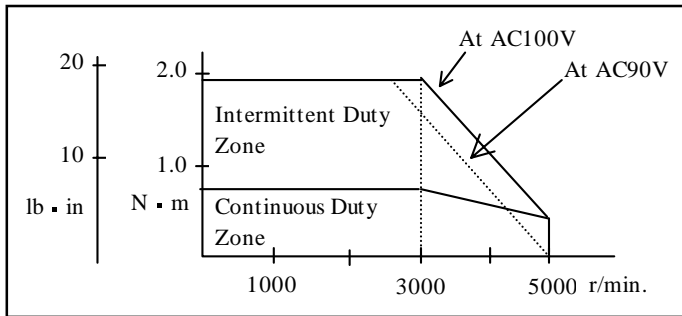

Temperature Characteristics

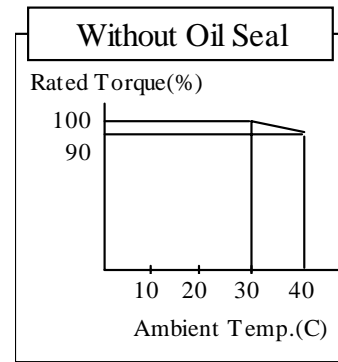

Permissible Radial and Thrust Loads

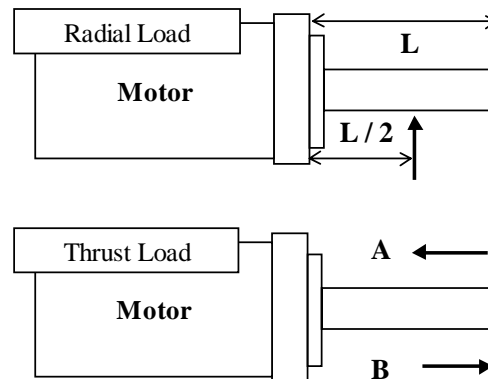

During Installation of Motor			During Operation of Motor	
Radial Load	Thrust A	Thrust B	Radial Load	Thrust Load
392.0 N	147.0 N	196.0 N	245.0 N	98.0 N
88.0 lb	33.0 lb	44.0 lb	55.0 lb	22.0 lb

MUMS022□□□ - 200W/200V

Specifications

Torque	Rated	N. m	0.64
		lb-in.	5.67
	Maximum	N. m	1.91
		lb-in.	16.92
Rotor Inertia	Without Brake	x10kg. ⁴ m ²	0.100
		lb. in ²	0.034
	With Brake	x10kg. ⁴ m ²	0.130
		lb. in ²	0.044
Speed	Rated	r/min.	3000
	Maximum	r/min.	5000
Weight	Without Brake	kg	0.96
		lb	2.12
	With Brake	kg	1.36
		lb	3.00
Current	Rated	A(rms)	1.6
	Maximum	A(0-P)	6.9
Power Rating	Without Brake	kW/s	41.4
	With Brake	kW/s	31.9
Brake (Option)	Voltage	V	DC 24 ± 2.4
	Current	DC, A	0.36
	Static Friction Torque	N. m	1.27 or higher
lb-in		11.24 or higher	

Note: Separate power source required for brake (DC24V)

Speed - Torque Curve

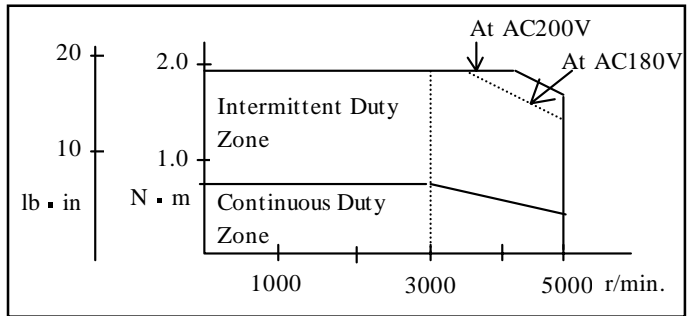

Temperature Characteristics

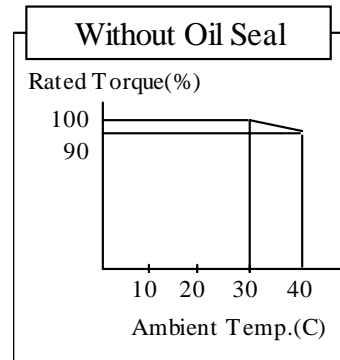

Permissible Radial and Thrust Loads

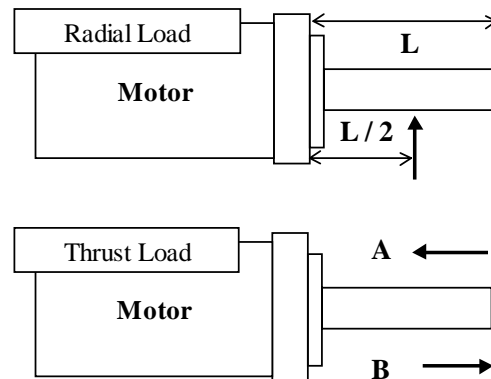

During Installation of Motor			During Operation of Motor	
Radial Load	Thrust A	Thrust B	Radial Load	Thrust Load
392.0 N	147.0 N	196.0 N	245.0 N	98.0 N
88.0 lb	33.0 lb	44.0 lb	55.0 lb	22.0 lb

MUMS022□□□ - 200W/200V

Dimensions

NEMA Flange #34 Type

Units: mm(in)

Drawing not to scale

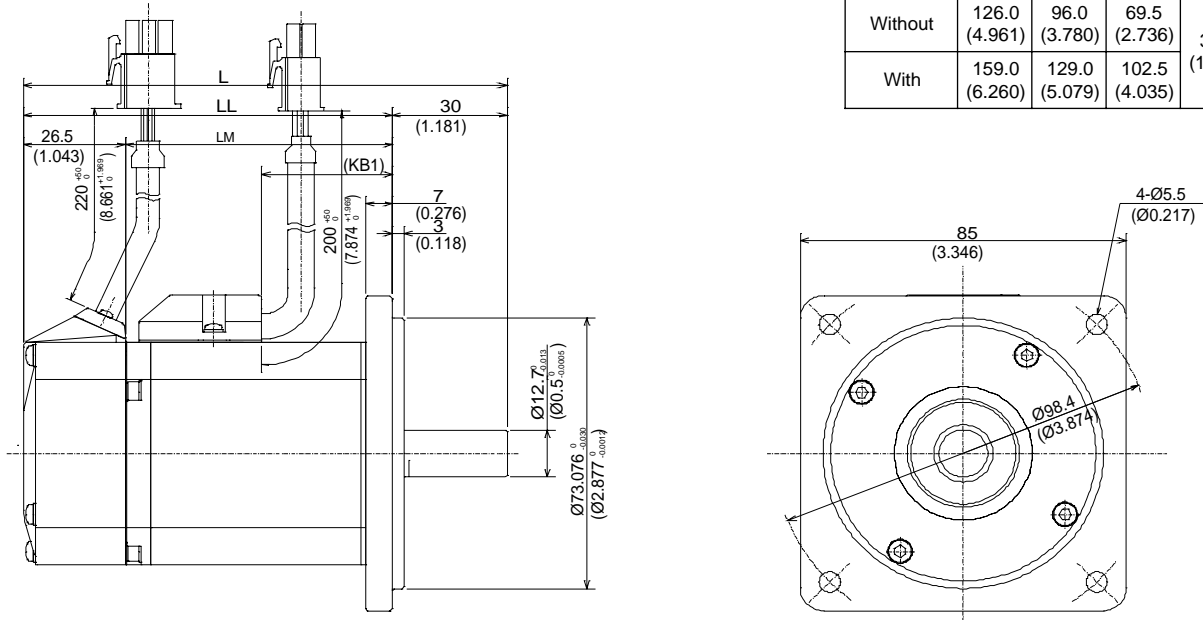

Stepping Flange Type

Drawing not to scale

Brake	L	LL	LM	KB1	S	LW	LK	KW	KH	RH
Without	126.0 (4.961)	97.5 (3.839)	71.0 (2.795)	35.5 (1.398)	11.0 (0.433)	20.0 (0.787)	18.0 (0.709)	4.0 (0.157)	4.0 (0.157)	8.5 (0.335)
With	159.0 (6.260)	130.5 (5.138)	104.0 (4.094)							

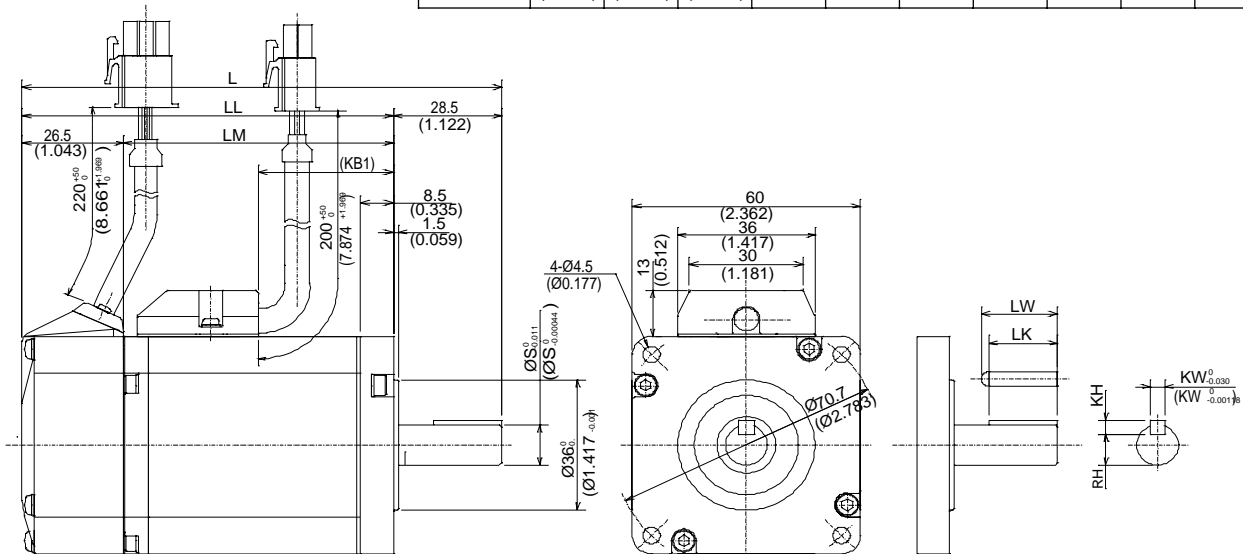

MUMS041□□□ - 400W/100V

Specifications

Torque	Rated	N. m	1.30
		lb-in.	11.51
	Maximum	N. m	3.80
		lb-in.	33.66
Rotor Inertia	Without Brake	x10kg· ⁴ m ²	0.170
		lb. in ²	0.058
	With Brake	x10kg· ⁴ m ²	0.200
		lb. in ²	0.068
Speed	Rated	r/min.	3000
	Maximum	r/min.	4500
Weight	Without Brake	kg	1.5
		lb	3.31
	With Brake	kg	1.9
		lb	4.19
Current	Rated	A(rms)	4.4
	Maximum	A(0-P)	18.6
Power Rating	Without Brake	kW/s	97.4
	With Brake	kW/s	82.8
Brake (Option)	Voltage	V	DC 24 ± 2.4
	Current	DC, A	0.36
	Static Friction Torque	N. m	1.27 or higher
		lb-in	11.24 or higher

Note: Separate power source required for brake (DC24V)

Speed - Torque Curve

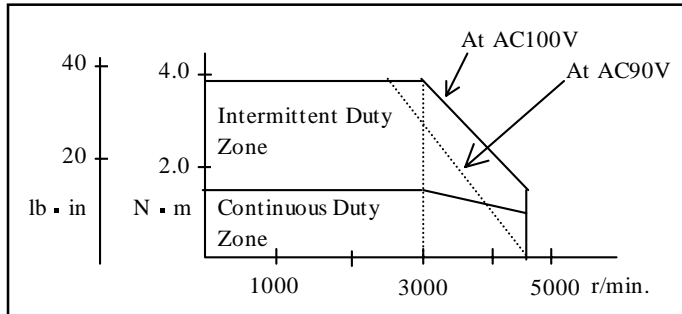

Temperature Characteristics

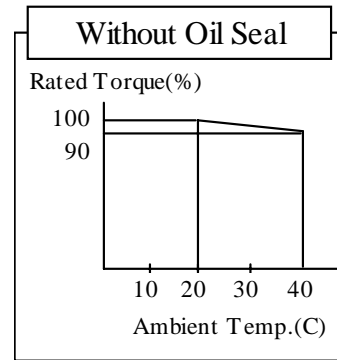

Permissible Radial and Thrust Loads

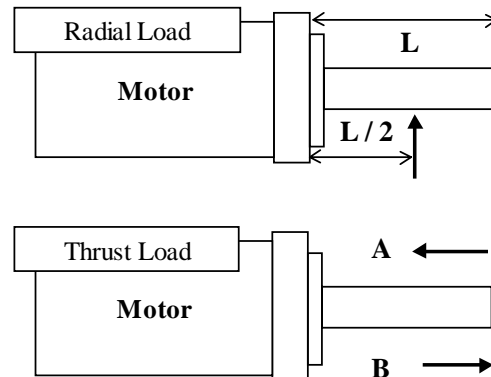

During Installation of Motor			During Operation of Motor	
Radial Load	Thrust A	Thrust B	Radial Load	Thrust Load
392.0 N	147.0 N	196.0 N	245.0 N	98.0 N
88.0 lb	33.0 lb	44.0 lb	55.0 lb	22.0 lb

MUMS042□□□ - 400W/200V

Specifications

Torque	Rated	N. m	1.30
		lb-in.	11.51
	Maximum	N. m	3.80
		lb-in.	33.66
Rotor Inertia	Without Brake	x10kg· ⁴ m ²	0.170
		lb. in ²	0.058
	With Brake	x10kg· ⁴ m ²	0.200
		lb. in ²	0.068
Speed	Rated	r/min.	3000
	Maximum	r/min.	5000
Weight	Without Brake	kg	1.5
		lb	3.31
	With Brake	kg	1.9
		lb	4.19
Current	Rated	A(rms)	2.5
	Maximum	A(0-P)	10.5
Power Rating	Without Brake	kW/s	97.4
	With Brake	kW/s	82.8
Brake (Option)	Voltage	V	DC 24 ± 2.4
	Current	DC, A	0.36
	Static Friction Torque	N. m	1.27 or higher
lb-in		11.24 or higher	

Note: Separate power source required for brake (DC24V)

Speed - Torque Curve

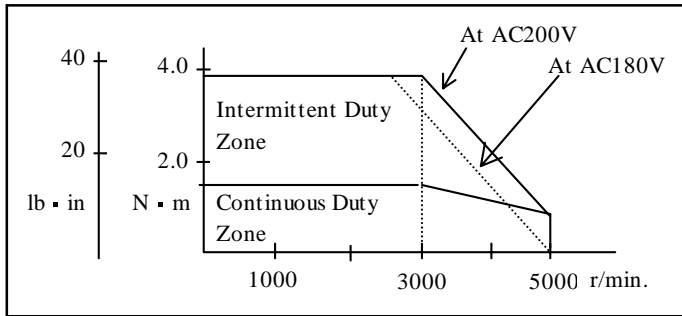

Temperature Characteristics

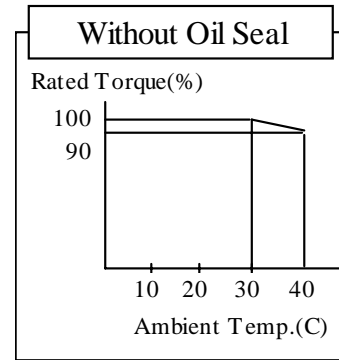

Permissible Radial and Thrust Loads

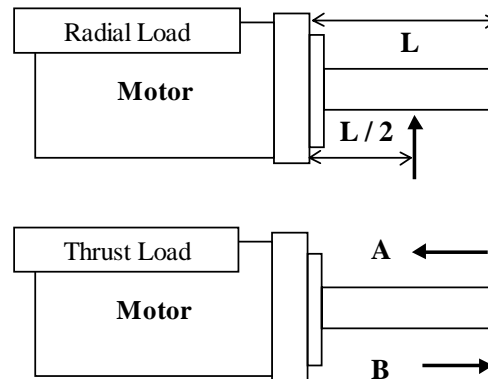

During Installation of Motor			During Operation of Motor	
Radial Load	Thrust A	Thrust B	Radial Load	Thrust Load
392.0 N	147.0 N	196.0 N	245.0 N	98.0 N
88.0 lb	33.0 lb	44.0 lb	55.0 lb	22.0 lb

MUMS042□□ - 400W/200V

Dimensions

NEMA Flange #34 Type

Units: mm(in)

Drawing not to scale

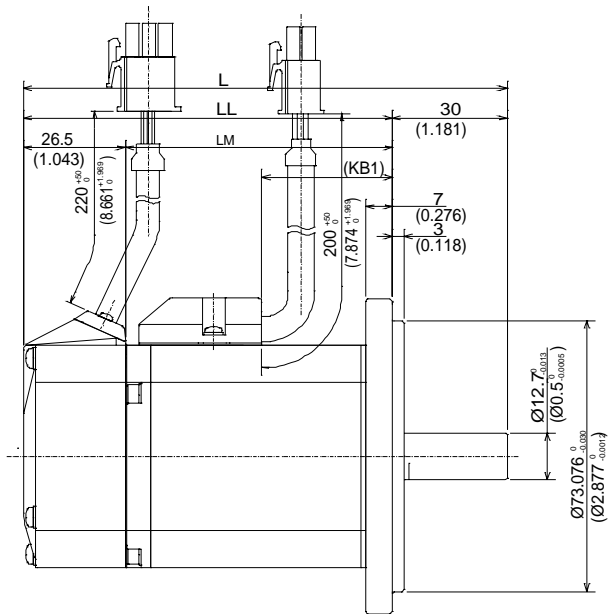

Brake	L	LL	LM	KB1
Without	153.5 (6.043)	123.5 (4.862)	97.0 (3.819)	61.5 (2.421)
With	186.5 (7.343)	156.5 (6.161)	130.0 (5.118)	

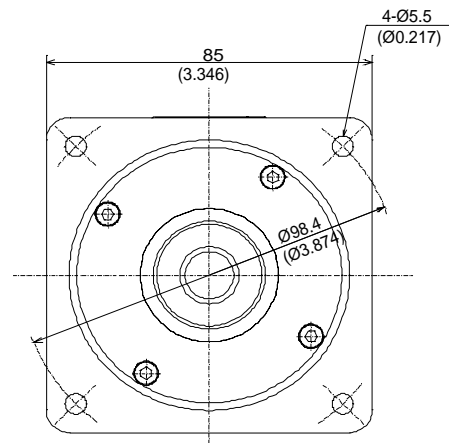

Stepping Flange Type

Drawing not to scale

Brake	L	LL	LM	KB1	S	LW	LK	KW	KH	RH
Without	153.5 (6.043)	125.0 (4.921)	98.5 (3.878)	63.0 (2.480)	14.0 (0.551)	25.0 (0.984)	22.5 (0.886)	5.0 (0.197)	5.0 (0.197)	11.0 (0.433)
With	186.5 (7.343)	158.0 (6.220)	131.5 (5.177)							

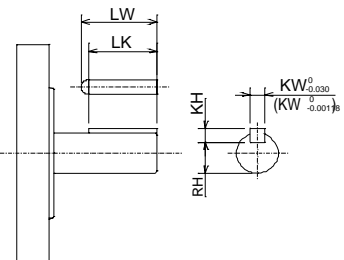
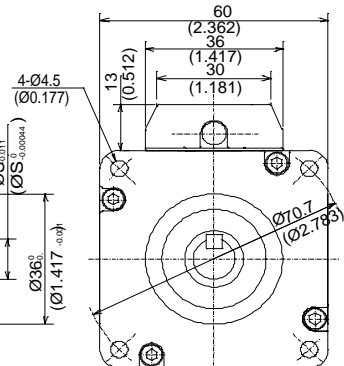
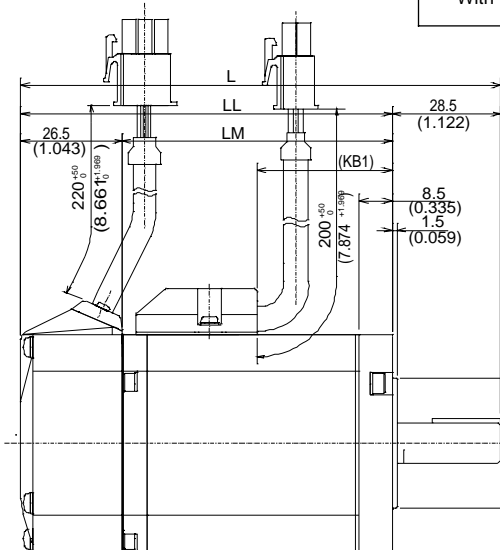

MUMS082□□□ - 750W/200V

Specifications

Torque	Rated	N. m	2.40
		lb-in.	21.26
	Maximum	N. m	7.10
		lb-in.	62.88
Rotor Inertia	Without Brake	x10kg.·4m ²	0.670
		lb. in ²	0.229
	With Brake	x10kg.·4m ²	0.750
		lb. in ²	0.256
Speed	Rated	r/min.	3000
	Maximum	r/min.	4500
Weight	Without Brake	kg	3.1
		lb	6.83
	With Brake	kg	3.8
		lb	8.38
Current	Rated	A(rms)	4.3
	Maximum	A(0-P)	18.3
Power Rating	Without Brake	kW/s	86.4
	With Brake	kW/s	77.2
Brake (Option)	Voltage	V	DC 24 ± 2.4
	Current	DC, A	0.43
	Static Friction Torque	N. m	2.45 or higher
lb-in		21.68 or higher	

Note: Separate power source required for brake (DC24V)

Speed - Torque Curve

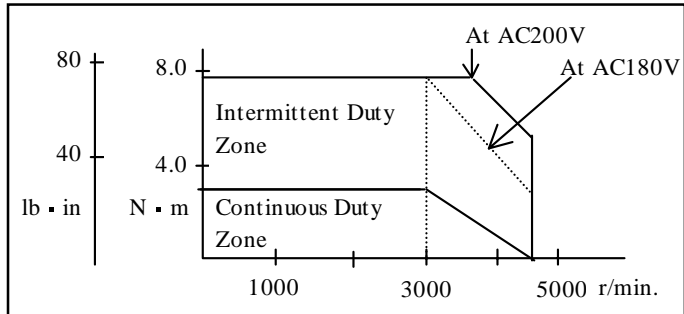

Temperature Characteristics

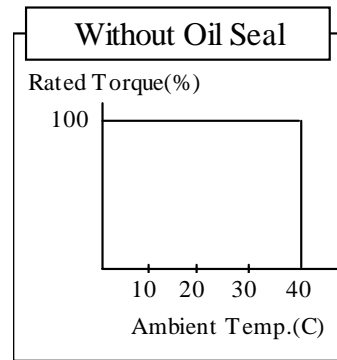

Permissible Radial and Thrust Loads

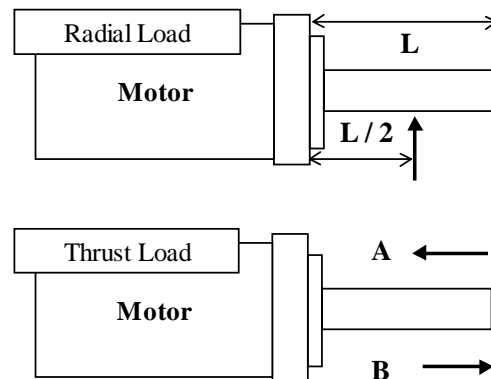

During Installation of Motor			During Operation of Motor	
Radial Load	Thrust A	Thrust B	Radial Load	Thrust Load
686.0 N	294.0 N	392.0 N	392.0 N	147.0 N
154.0 lb	66.0 lb	88.0 lb	88.0 lb	33.0 lb

MUMS082 - 750W/200V

Dimensions

NEMA Flange #34 Type

Drawing not to scale

Units: mm(in)

Brake	L	LL	LM	KB1	S
Without	177.5 (6.988)	142.5 (5.610)	113.0 (4.449)	76.0 (2.992)	15.875 (0.625)
With	211.5 (8.327)	176.5 (6.949)	147.0 (5.787)		

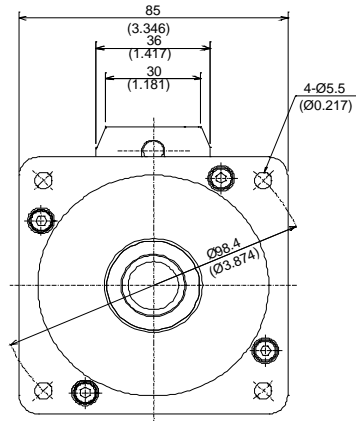
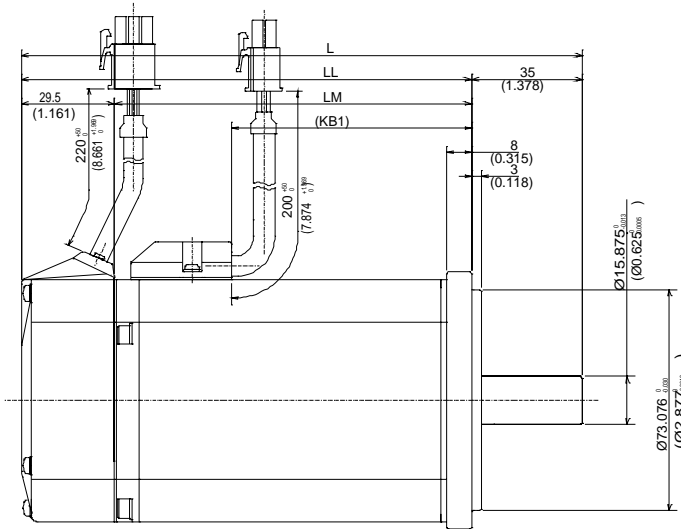

Stepping Flange Type

Drawing not to scale

Brake	L	LL	LM	KB1	S	LW	LK	KW	KH	RH
Without	177.5 (6.988)	143.5 (5.650)	114.0 (4.488)	77.0 (0.984)	19.0 (0.748)	25.0 (0.984)	22.0 (0.866)	6.0 (0.236)	6.0 (0.236)	15.5 (0.610)
With	211.5 (8.327)	177.5 (6.988)	148.0 (5.827)							

